

CS2100 Computer Organization
AY2024/25 Semester 1
Assignment 3
(Deadline: 4 November 2024, Monday, 1pm)

Instructions

1. There are **9** questions in this assignment, totaling TWENTY (20) marks.
2. This assignment is due on **Monday, 4 November 2024, 1 pm**. The submission folder will be closed at 1:10 pm, **after which no submission will be accepted and you will receive ZERO for this assignment.**
3. Answer these questions on Canvas > Quizzes > Assignment 3.
4. You should do these assignments on your own. Do not discuss the assignment questions with others.
5. As this assignment is autograded, please follow the instructions carefully.
6. Please post on QnA “Assignments” topic if you have any queries.

Note that unless otherwise stated, complemented literals are not available. Constants 1 (true) and 0 (false) are always available. This instruction applies to the final exam and it may not be repeated there.

Important Instructions (don't skip this!):

For Questions 1 – 5, when listing out the minterms/maxterms, you are to write them in increasing order of the minterm/maxterm numbers. For example, if the answer is $\Sigma m(1, 2, 3, 5)$, enter **1,2,3,5** (separated by comma, no other punctuation besides commas, and without any space). Answers such as **1, 2, 3, 5** (with additional spaces), **1,5,2,3** (not in increasing order), and **1,2,3,3,5** (duplicate numbers) will all be graded as wrong. There will be no partial credit. Pay attention to the order of the variables in the given function. All the questions in this assignment are autograded.

Question 1. (2 marks)

The diagram below shows a 2x4 decoder with one-enable and active-high outputs. Fill in the list of minterms for $F1(A,B,C,D)$ in the Σm notation (sum-of-minterms), i.e. $F1(A,B,C,D) = \Sigma m(\dots)$.

(Read the "Important Instructions".)

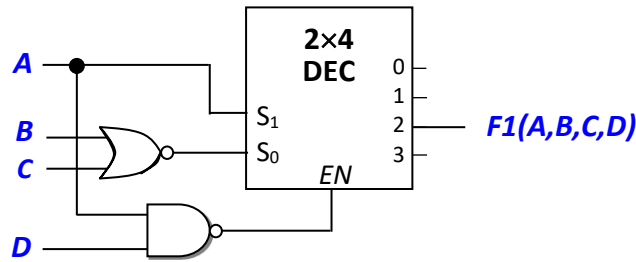

Question 2. (2 marks)

The diagram below shows a 2x4 decoder with one-enable and active-high outputs. Fill in the list of minterms for $F2(D,C,B,A)$ in the Σm notation (sum-of-minterms), i.e. $F2(D,C,B,A) = \Sigma m(\dots)$.

(Read the "Important Instructions".)

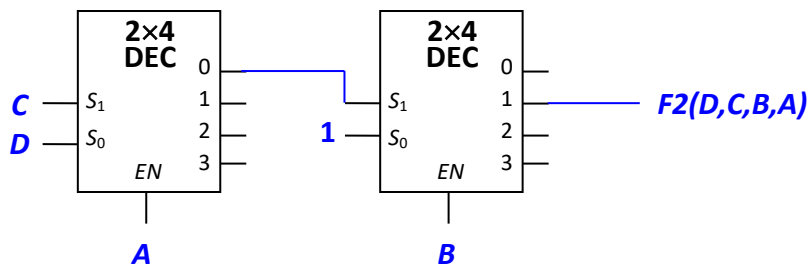

Question 3. (2 marks)

The diagram below shows a 2x4 decoder with zero-enable and active-low outputs. Fill in the list of minterms for $F3(X,Y,Z)$ in the Σm notation (sum-of-minterms), i.e. $F3(X,Y,Z) = \Sigma m(\dots)$.

(Read the "Important Instructions".)

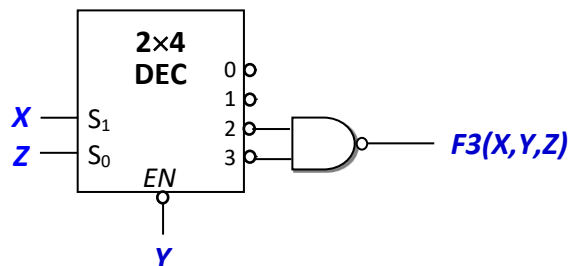

Question 4. (2 marks)

The diagram below shows a 4:1 multiplexer. Fill in the list of maxterms for $F4(A,B,C)$ in the ΠM notation (product-of-maxterms), i.e. $F4(A,B,C) = \Pi M(\dots)$.

(Read the "Important Instructions".)

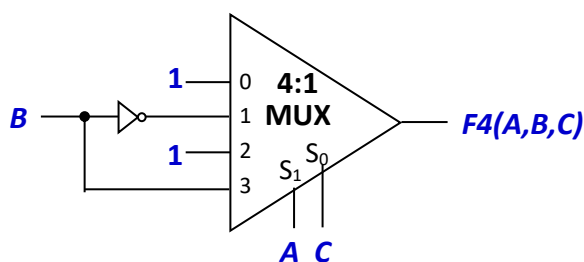

Question 5. (2 marks)

The diagram below shows a 4-bit magnitude comparator and a 2×4 decoder with 1-enable and active-high outputs. What is $F5(A,B,C,D)$ in Σm notation (sum-of-minterms)? List out the minterms.

(Read the “Important Instructions”.)

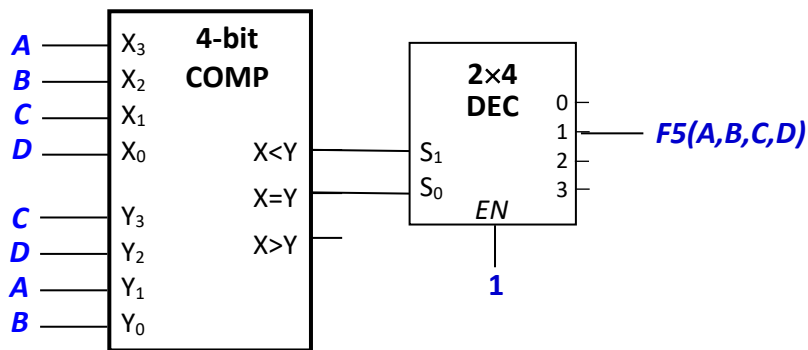

Question 6. (2 marks)

The diagram below shows a 4-bit magnitude comparator. What is the simplified SOP expression of $F6(A,B,C,D)$?

Shorter product terms must be written before longer product terms. For product terms with the same length, they can be written in any order. If a product term contains more than one literal, you must have the dot (AND) symbol, or your answer will be considered wrong. Within a product term, the literals should be in alphabetical order. Literals should be in upper-case letters, and there should be no space, no parenthesis, and no symbols other than the dot, plus and single quote in your answer.

Use the plaintext plus (+), dot (.), and single quote (') instead of the LaTeX option in your answer.

Important: Do NOT paste your answer from Word document into Canvas as the smart quotation mark in Word will not be recognized by Canvas, hence resulting in your answer being graded as wrong.

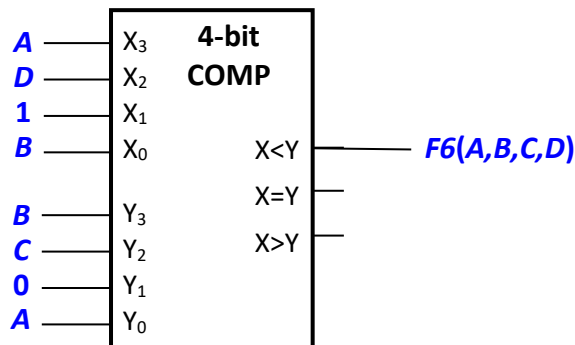

Question 7. (2 marks)

A Boolean function $Z(P,Q,R)$ is implemented using a half adder, two inverters, and a 4-to-2 priority encoder as shown below. The function tables of the half adder and the priority encoder are also shown below.

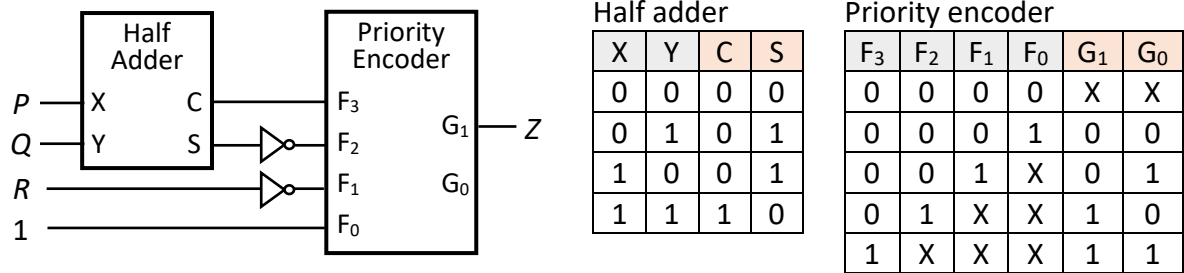

The circuit above may be replaced by a single 2-input logic gate. Choose the logic gate from this list: OR, AND, NOR, NAND, XOR, XNOR.

Question 8. (Total: 3 marks)

A sequential circuit with state ABC is shown below.

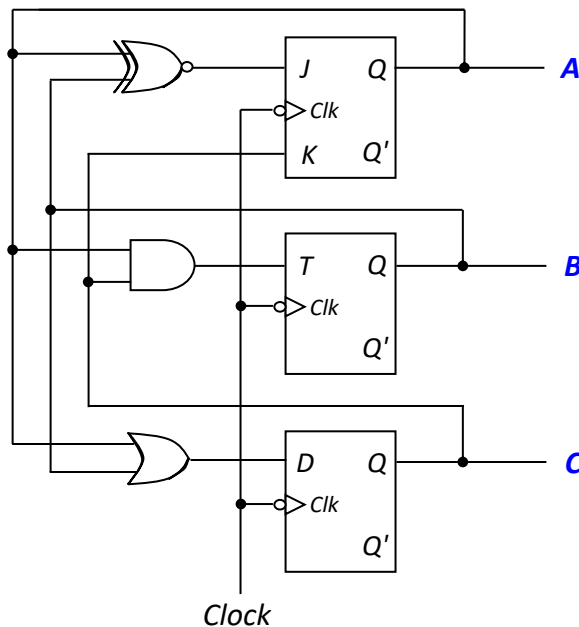

All answers should be in decimal, not binary.

- (a) If the initial state is 0 ($ABC = 000$), what state is the circuit in after 2 clock cycles? [1 mark]
- (b) If the initial state is 6 ($ABC = 110$), what state is the circuit in after 2 clock cycles? [1 mark]
- (c) Identify all the sink states in this circuit. If there are more than one sink state, write them in ascending order, separated by comma, without any space. There should be no punctuation other than comma. If there are no sink states, write none. [1 mark]

Question 9. (Total: 3 marks)

A sequential circuit goes through the following states, whose state values are shown in decimal:

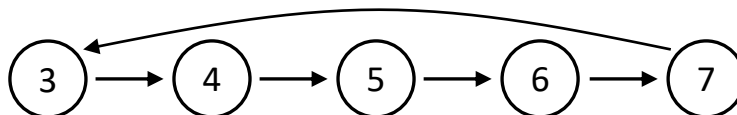

The states are represented by 3-bit values ABC . Implement the sequential circuit using a JK flip-flop for A , a T flip-flop for B , and a D flip-flop for C .

Write the simplified SOP expression for each of the following flip-flop inputs. For each product term in your SOP expression, write the literals in alphabetical order. Literals should be in upper-case letters, and there should be no space, no parenthesis, and no symbols other than the dot, plus and single quote in your answer.

Use the plaintext plus (+), dot (.), and single quote (') instead of the LaTeX option in your answer.

Important: Do NOT paste your answer from Word document into Canvas as the smart quotation mark in Word will not be recognized by Canvas, hence resulting in your answer being graded as wrong.

(a) Flip-flop input KA [1 mark]; (b) Flip-flop input TB [1 mark]; (c) Flip-flop input DC [1 mark]

=== END OF PAPER ===